

PATIOS OPEN TO SKY (INCLUDES WALKWAYS)
BUILDING PERMIT APPLICATION

Application Date ____/____/____

Property & Owner Information	
Owner Name or Business Name	
Phone	
Street Address	Romeoville, Illinois 60446
Email Address	
Subdivision & Lot #	Subdivision _____ Lot # _____
Who is the applicant?	<input type="checkbox"/> Owner <input type="checkbox"/> Renter <input type="checkbox"/> Contractor
Who will be doing the work? Check all that apply.	<input type="checkbox"/> Self <input type="checkbox"/> General Contractor <input type="checkbox"/> Sub-Contractor(s)
Who is the contact person?	<input type="checkbox"/> Homeowner <input type="checkbox"/> Contractor
Estimated Cost of Patio	\$ _____

Contractor Information	
If using a contractor or sub-contractor, a copy of the contract must be included with the application and the following information must be provided. All contractors and sub-contractors in Romeoville must be registered with the Village.	
Contractor Name	
Contractor Address	
Email Address	
Contractor Phone	
Village Registration No.	
Work Performed by Homeowner	
If you doing the work yourself, please also complete the <i>Property Owner's Acknowledgement of Responsibility</i> form.	

Office Use Only	
Application Date:	Received By:
Permit Date:	Permit #:

Status Sticker
OFFICIAL USE ONLY

The Village of Romeoville has codes that guide the size and location of patios. Use this form and checklist as you plan your patio to ensure that you include all information needed to review your application. Please note that this form is designed to assist you in submitting an application for a patio that is open to the sky. It addresses the most common questions asked by residents. Please refer to the Village's Code of Ordinance for more detailed specifications.

Site Requirements

Requirement	✓ to confirm that you have shown ...	Office Use
You must submit a Plat of Survey or scaled plot plan which shows all structures on the lot, including the home, decks, porches, sheds, garages, pools, gazebos, etc. The structures must be drawn to scale, labeled, and dimensioned. <i>Please refer to Page 3 for an example.</i>	all structures	
The patio must be shown. It must be labeled and dimensioned.	the proposed structure	
The patio may not be on an easement, except with the written permission of the Village and all utility companies having rights to the easement.	the structure not located on any easement	
The patio must be at least 5 feet from the side property line.	the distance to the side property line	
The patio must be at least 10 feet from the rear property line. <i>However, if the property is zoned R-5A (Hampton Park, Poplar Ridge & Honeytree Unit 5,) the structure must be at least 7 feet to the rear property line.</i>	the distance to the rear property line	

Requirement	Fill in the blanks.	Office Use
<p>A patio, that is open to the sky, may be located in the rear yard (shown as 'b' on the diagram) or side yard (shown as 'c' on the diagram).</p> <p>YARDS a: Front b: Rear c: Side d: Corner Side</p>	<p>In which yard is the proposed structure: _____ Yard</p>	
In total, no more that 50% of the property can be covered with building, structures, or pavement.	<p>Size of proposed patio: _____ % of lot covered with structures: _____%</p>	

SAMPLE PLOT PLAN

This illustration is provided as an example of what must be submitted with your application. Please note that it must show:

- The size of the lot
- The location and size of the house
- The location and size of all existing structures
- The location of the proposed patio
- The size of the proposed patio
- The distance from the patio to the rear property line
- The distance from the patio to the side property line

All of this information must be shown on your plat so that we can review your application.

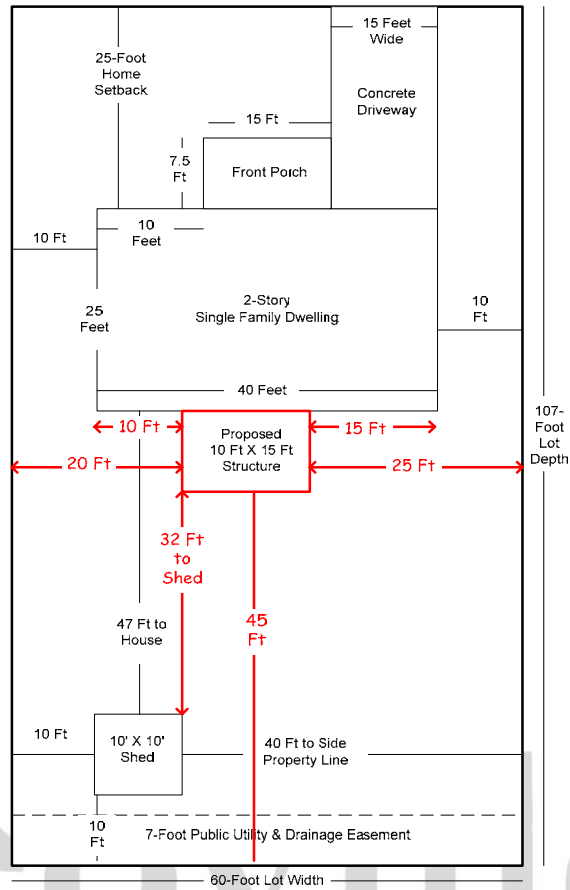

Construction Requirements

<i>Please read the requirements and place a ✓ in the column to the left to confirm that you understand and agree.</i>		Office Use
	All sod, topsoil, and organic material shall be removed to a sub-grade that reveals good bearing soil (clay).	
	Additives are <u>not</u> allowed in the concrete.	
	The patio must slope away from the residence or foundation to allow for drainage.	
	All work performed must be in compliance with all of the relevant codes and standards adopted by the Village of Romeoville which regulate the construction, alteration, addition, repair, removal, demolition, use, location, occupation and maintenance of all buildings and structures.	
	48 hours before digging, you must call JULIE utility locator at (800)892-0123. They will ask for the County (Will), Village (Romeoville), township, section and ¼ section. Please refer to the legal description on your Plat of Survey for this information.	
Requirement	Fill in the blanks.	Office Use
A maximum, ¾ inch gravel, ½ inch crushed stone or CA6 (road mix) shall be used as a base course placed on a sub-grade to a depth of not less than four (4) inches. The base course must be mechanically compacted.	What base course material will be used? _____ What depth is the base course? _____ Inches	
Wire mesh or approved equivalent shall be used as a	What material will be used for reinforcement?	

reinforcement	_____	
Patio slabs must be monolithically poured (as one uniform piece) to a minimum thickness of four (4) inches.	What will be the thickness of the slab? _____ Inches	
Concrete used for the slab must be a minimum 5 bag mix.	What will be the bag mix? _____ Mix _____ Bag	

Permit & Inspection Requirements		Office Use
<i>Please read the requirements and place a ✓ in the column to the left to confirm that you understand and agree.</i>		
	The Building Permit must be posted in the building's window where it can be seen from the street.	
	<p>Each phase of construction must be inspected and approved by the Village of Romeoville prior to proceeding to the next stage of construction.</p> <ul style="list-style-type: none"> • A Pre-Pour Inspection must be performed once the base course and forms are in and before pouring concrete. • A final inspection must be performed when the patio has been installed. If the inspection is passed, a Certificate of Completion will be issued. The patio may not be used until the Certificate of Completion has been issued. • All inspections must be scheduled 48 hours in advance by calling (815)886-7203 or by emailing buildinginspections@romeoville.org. A permit number must be provided when inspections are scheduled. • Failure to call for required inspections may result in a "Stop Work Order". • Should you fail an inspection, a re-inspection fee must be paid before continuing work and before scheduling another inspection. 	
	Work must be started within thirty (30) days of the issuance date of the permit and must be completed within 365 days.	

I hereby declare that I have read and understood this application. The above information and any attachments are correct. I agree, that in consideration of and upon issuance of a building or use permit, that I am allowed to do such work as herewith applied for, and that such premises shall be used only for such purposes as set forth above.

I hereby certify that I am the owner of record of the named property, or that the proposed work is authorized by the owner of record and that I have been authorized by the owner to make this application as his authorized agent and I agree to conform to all applicable laws of this jurisdiction. In addition, if a permit for work described in this application is issued, I certify that the code official or the code official's authorized representative shall have the authority to enter areas covered by such permit at any reasonable hour to enforce the provisions of the code(s) applicable to such permit.

Signature of Applicant: _____ Date: _____

This Page for Office Use Only

Approval & Review Status

Building	Date Plans Received	
	Plans Examiner	
	Date Plans Approved	
	Plans Approved By	

Planning:	Date Plans Received	
	Plans Examiner	
	Date Plans Approved	
	Plans Approved By	

Clerical	Contacted Date:	
	Person Contacted:	
	Contacted By:	
	Permit Received:	

Notes	
-------	--